

RETENUE DE COULISSE A ROULEAU

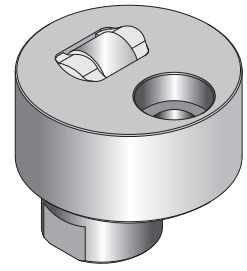
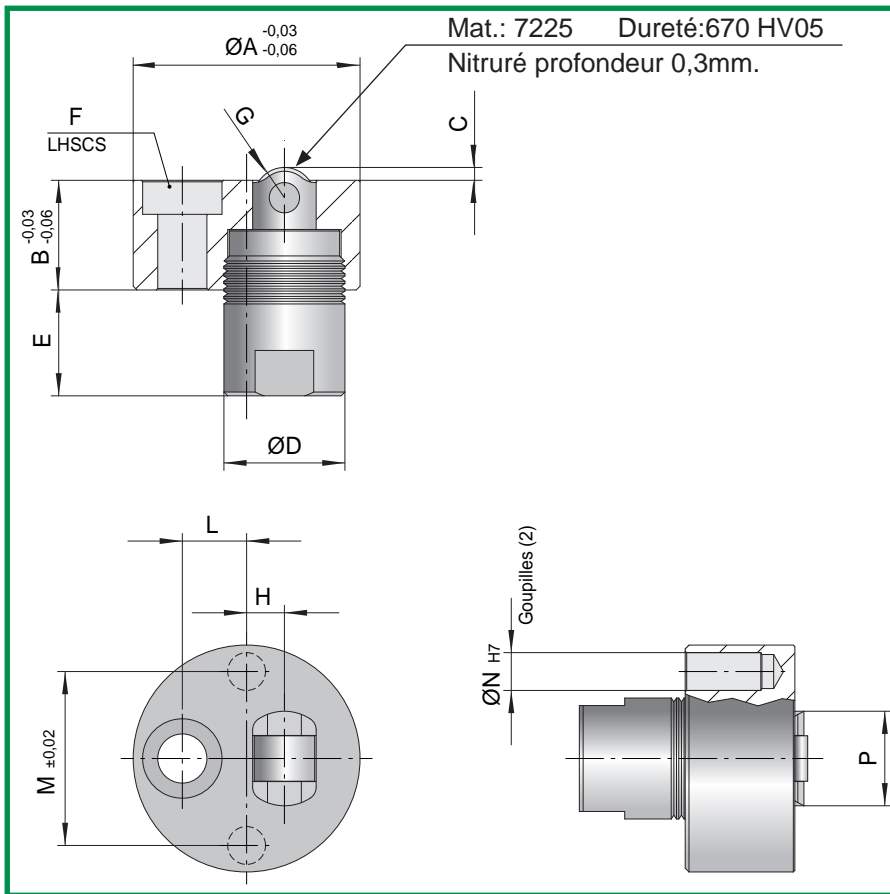

CODE: **RIT..**

K= charge maximale

CODE	A	B	C	D	E	F	G	H	L	M	N	P	K
RIT10	25	11,5	1	14	14	M5	6	3	7,5	18	4	10,5	10Kg
RIT20	30	14,5	1,5	16	14	M6	8	5	8,5	23	5	12,5	20Kg
RIT50	40	19,5	2	22	18	M8	12	7	11	30	6	18,5	50Kg

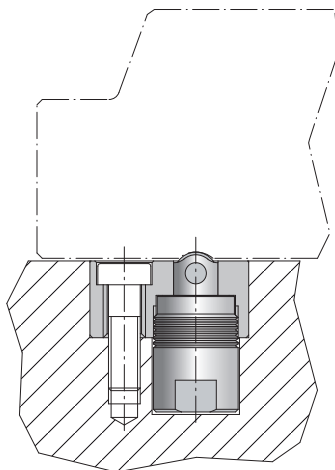

CODE	Q	R
RIT10	1	3
RIT20	1,5	4
RIT50	2	6

CARACTERISTIQUES

- 1) FAIBLE FRICTION ENTRE LES ÉLÉMENTS GLISSANTS ;
- 2) HAUTE CAPACITÉ DE CHARGE;
- 3) DESIGN ROBUSTE .