

TRASCINATORE PER DOPPIA ESTRAZIONE

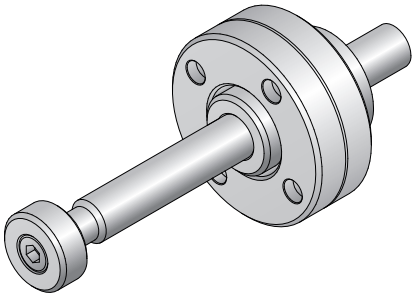

COD.: **AS-...**

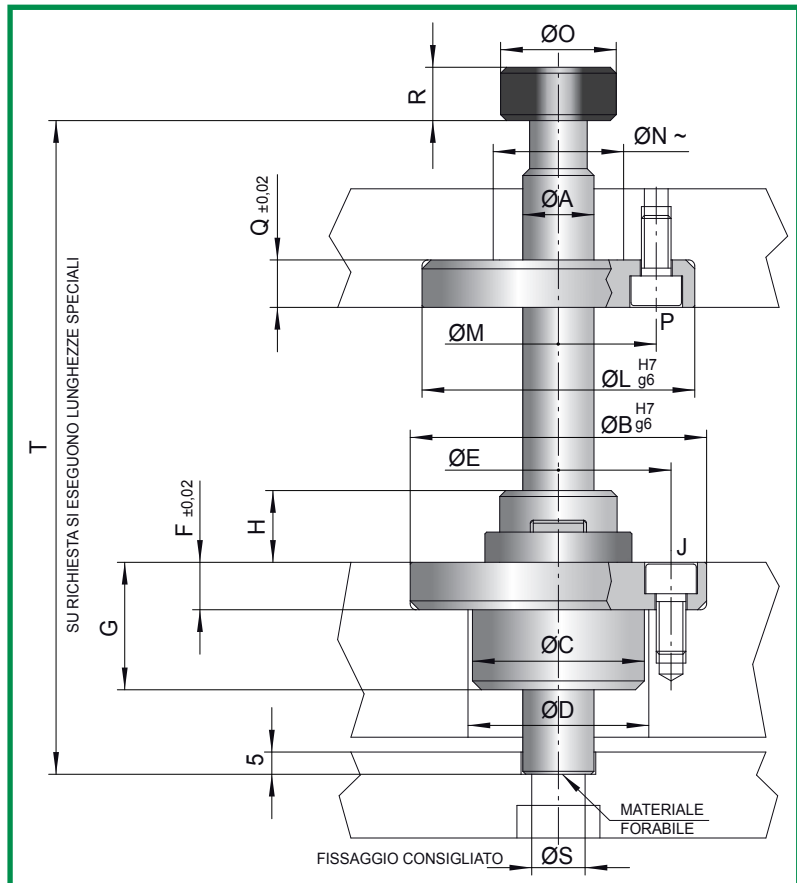

COD.	A	B	C	D	E	F	G	H	J	L	M	N	O	P	Q	R	S	T
AS-12C	12	50	29	29,5	38	8	21,5	12	M5-n°4	46	33	22	19,5	M5-n°4	8	9	M8	100
AS-12L																		200
AS-16C	16	70	41	41,5	52	13	28	17	M8-n°4	70	52	33	29	M8-n°4	13	12	M10	100
AS-16L																		200
AS-32	32	125	82	82,5	101	25	50	38,5	M10-n°6	125	101	50	45	M10-n°6	25	29	M16	500

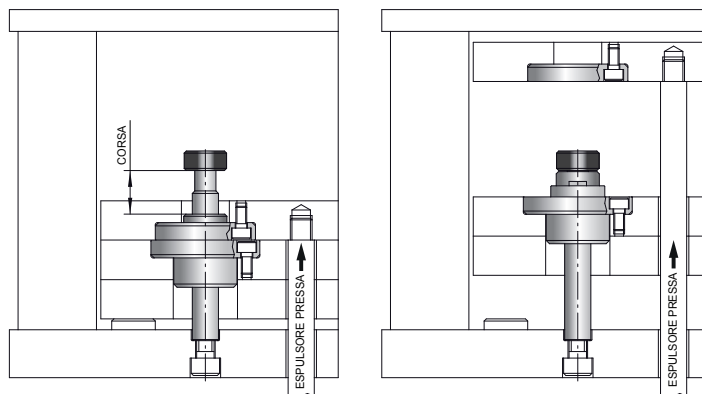

CARATTERISTICHE

- 1) FACILITÀ DI APPLICAZIONE;
- 2) VERSATILITÀ DI IMPIEGO;
- 3) BLOCCAGGIO DELLA PIASTRA TRASCINATA DOPO LO SGANCIO;
- 4) SENZA LIMITE DI CORSA.

IN CASO DI APPLICAZIONI INCERTE CONSULTARE IL COSTRUTTORE.

ERMANN BALZI

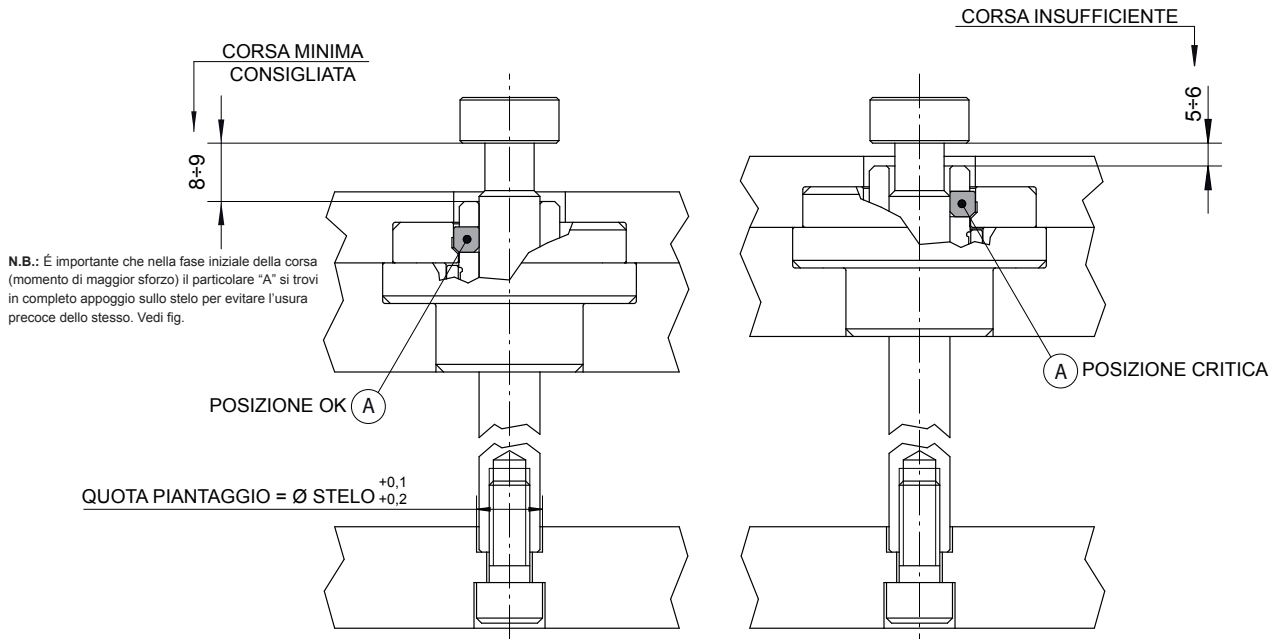

ESEMPIO DI APPLICAZIONE

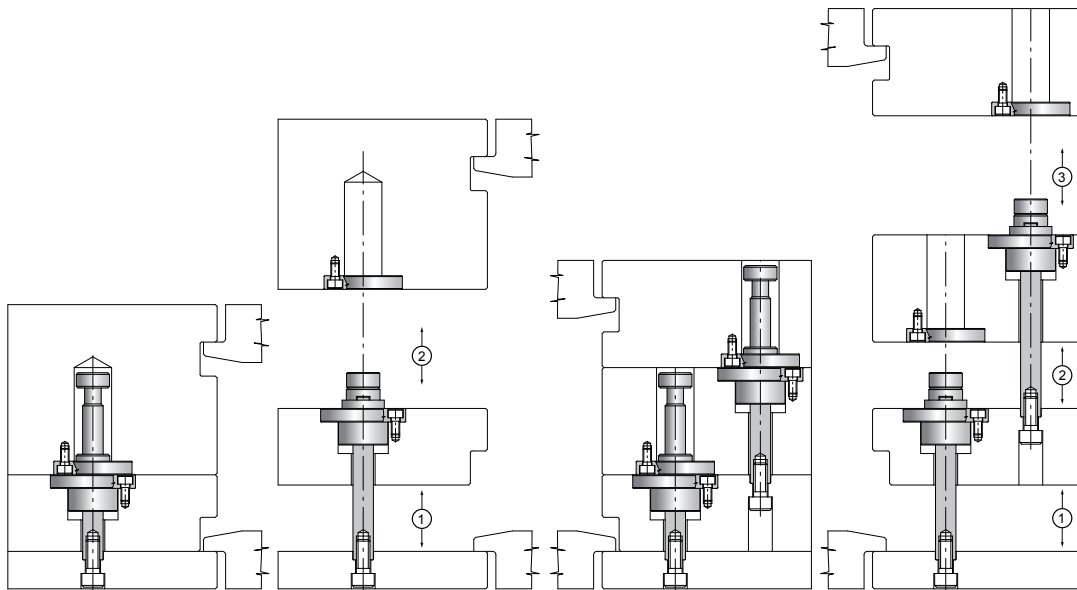

APPLICAZIONE SPECIALE

