

(拥有专利的系统)

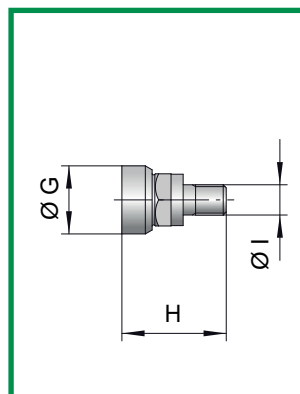
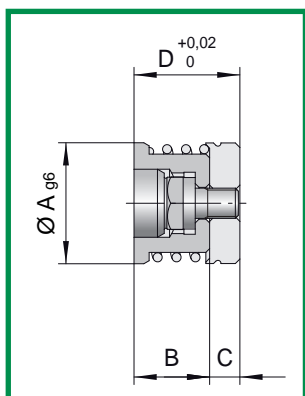

全套日期戳

A	B	C	D
6	7	3	10
8	8	4	12
10	10	4	14
12	10	4	14
16	10	4	14

材料: AISI 420B
硬度: 50÷55 HRC

可互换插件

G	H	I
3,8	10	M2,5
5	12	M3
6	14	M3
7	14	M4
9	14	M4

材料: AISI 420B
硬度: 48÷50 HRC

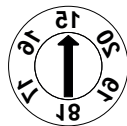

订单编号	订单编号	订单编号
DA-MFA6	DA-MF6	DA-AF6
DA-MFA8	DA-MF8	DA-AF8
DA-MFA10	DA-MF10	DA-AF10
DA-MFA12	DA-MF12	DA-AF12
DA-MFA16	DA-MF16	DA-AF16



订单编号	订单编号
ID-FA6	ID-F6
ID-FA8	ID-F8
ID-FA10	ID-F10
ID-FA12	ID-F12
ID-FA16	ID-F16

配备环形螺母

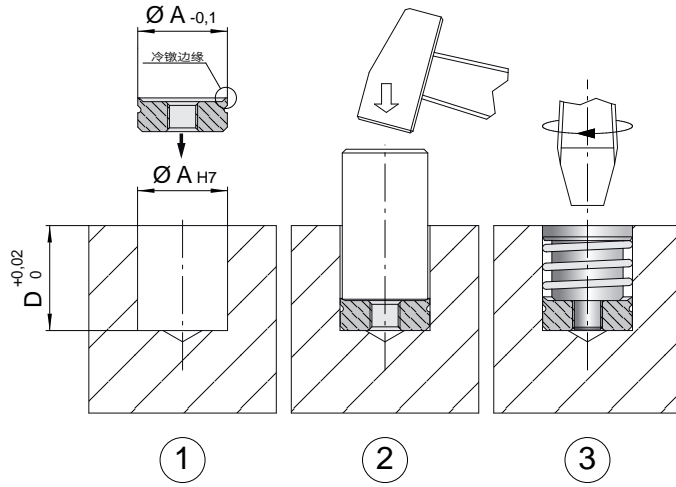

在模板内加工出螺纹

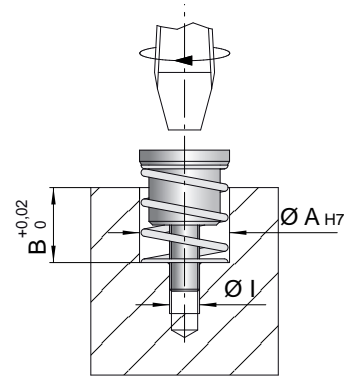

注

- 1) 插入环形螺母，使冷头端边缘向上；
- 2) 插入相同直径的冲头后对边缘进行冷头冲压；
- 3) 插入日期戳并用螺丝刀拧紧。

注：用于压印每天日期的DA-G日期戳（各种直径）只能用环形螺母插入。