

RAPID PLUG AND UNPLUG SYSTEM (PATENTED SYSTEM)

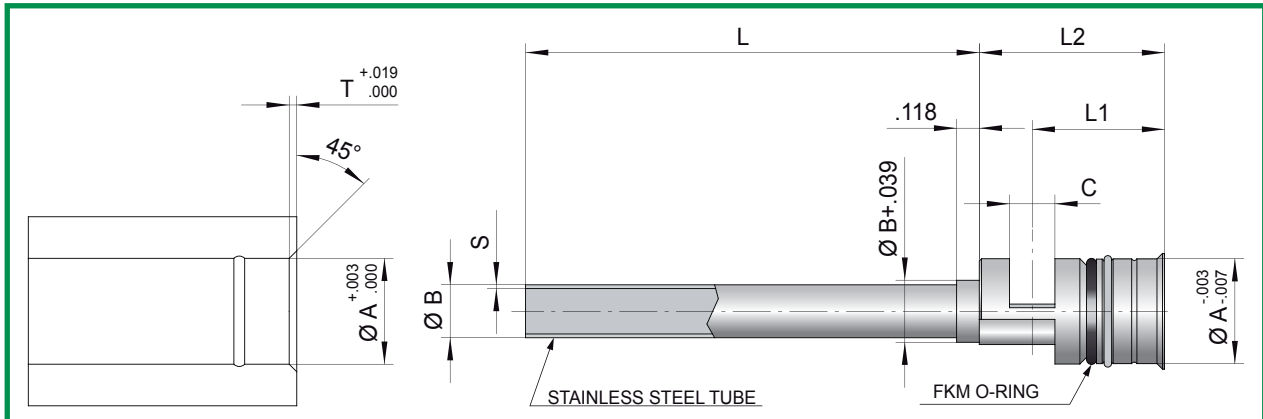
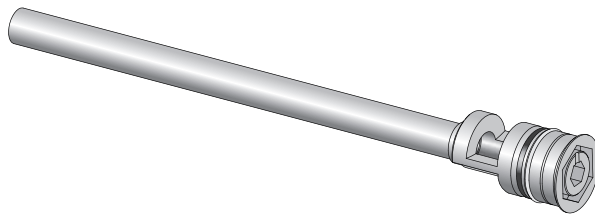

CODE: **RF-..F**

CODE	A	T	B			S	C	L1	L2	L			
RF-Q	.338	.039	.078	.118	.157	.009	.157	.511	.708	4	8	12	
RF-7/16	.437	.039	.098	.118	.157	.196	.009	.196	.649	.866	4	8	12
RF-37/64	.577	.039	.275			.019	.236	.688	.964	4	8	12	
RF-23/32	.718	.047	.314			.019	.314	.748	1.082	6	12	18	24
RF-59/64	.921	.047	.472			.039	.393	.787	1.161	6	12	18	24
RF-1" 5/32	1.156	.047	.590			.039	.472	.885	1.318	6	12	18	24

Order example: RF-7/16x6/.0981

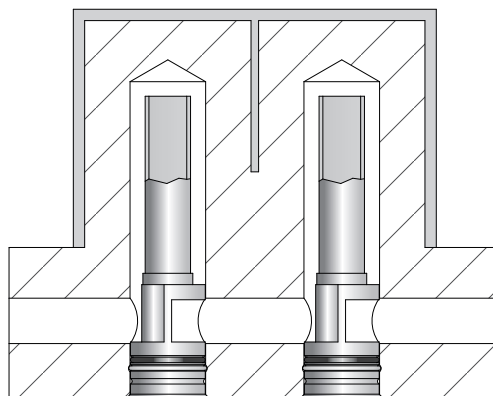

CHARACTERISTICS

- 1) RAPID SLOTTING;
- 2) RAPID FITTING AND REMOVING;
- 3) VERSATILITY OF POSITIONING (due to the shape of the inlet and outlet liquid discharges);
- 4) SECURE SEAL IS MAINTAINED EVEN UNDER HIGH PRESSURE CONDITIONS (~100 BAR).

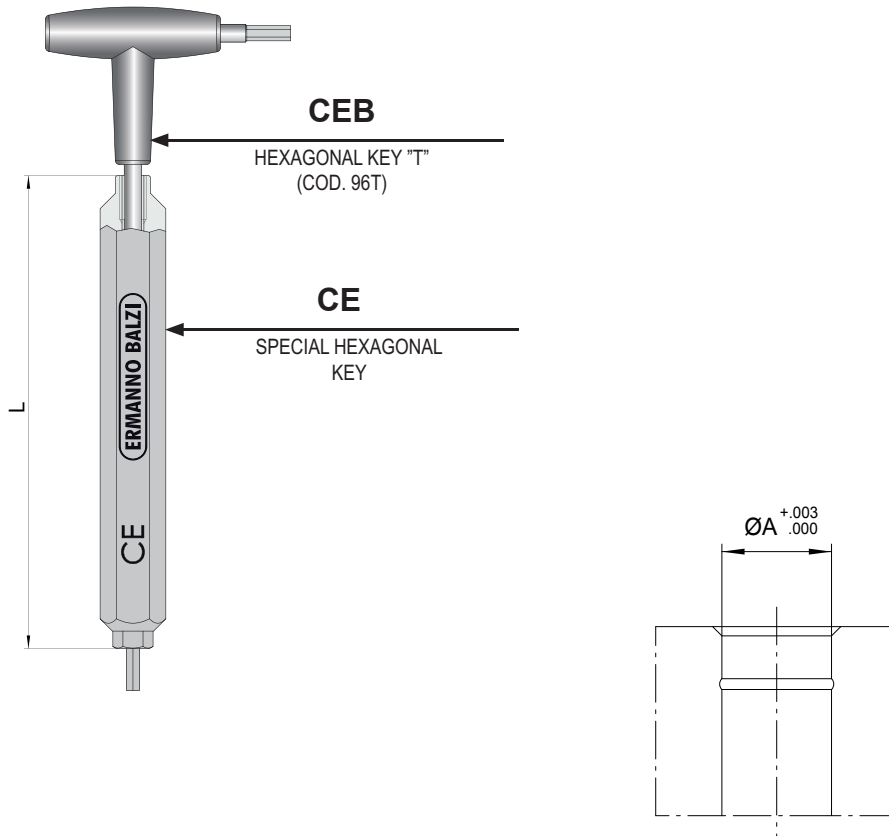

CODE	ØA
CE-5	TR-1/4
CEB-2	

CODE	ØA
CE-6,5	TR-Q
CEB-2,5	

CODE	ØA
CE-8	TR-7/16
CEB-3	
CE-8	TR-37/64
CEB-3	

CODE	ØA
CE-12	TR-23/32
CEB-5	TR-59/64
	TR-1"-5/32

TOOLS FOR THE PERFORMING OF THE RETAINING GROOVE

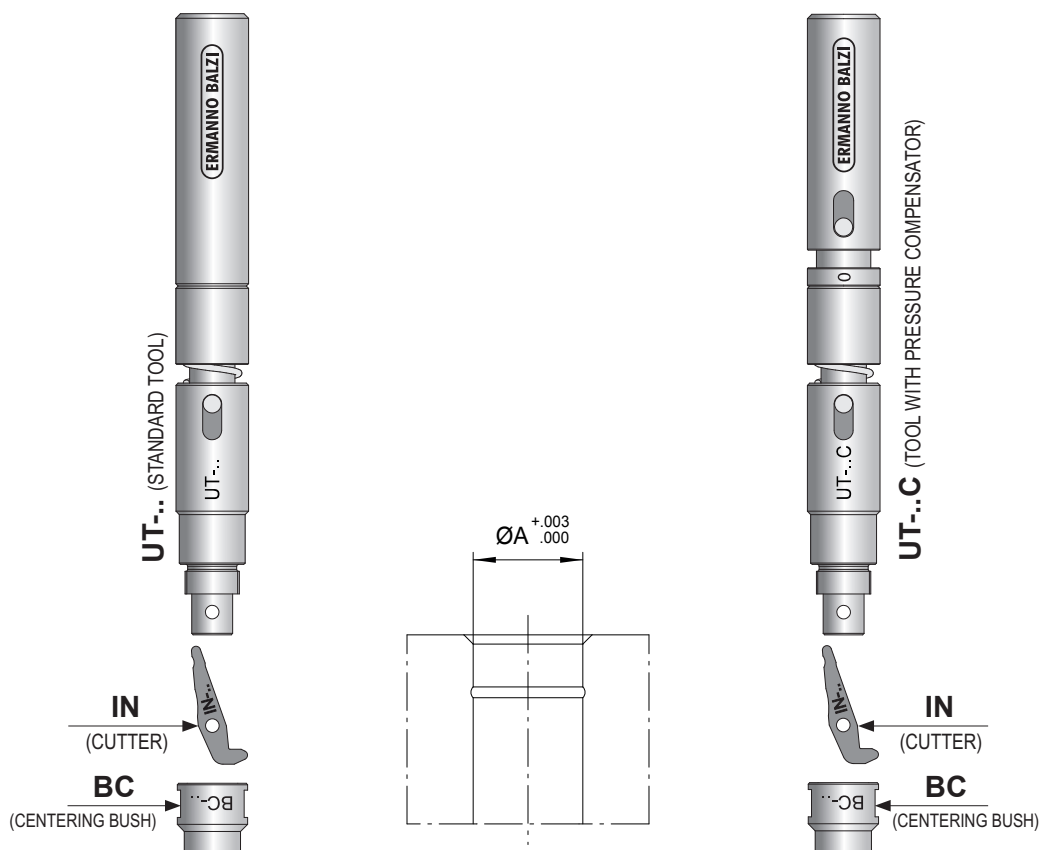

CODE	$\varnothing A$	BC	IN
UT-1 UT-1C	TR-1/4	BC-1/4	IN-1/4

CODE	$\varnothing A$	BC	IN
UT-2 UT-2C	TR-Q	BC-Q	IN-Q

CODE	$\varnothing A$	BC	IN
UT-3 UT-3C	TR-7/16	BC-7/16	IN-7/16
	TR-37/64	BC-37/64	IN-37/64

CODE	$\varnothing A$	BC	IN
UT-4 UT-4C	TR-23/32	BC-23/32	IN-23/32
	TR-59/64	BC-59/64	IN-59/64
	TR-1"-5/32	BC-1"-5/32	IN-1"-5/32

STANDARD CUTTER		
CODE	CUTTING SPEED in/min.	RPM
IN-1/4	.156÷.183	500÷600
IN-Q	.156÷.183	460÷550
IN-7/16	.156÷.183	370÷450
IN-37/64	.156÷.183	350÷420
IN-23/32	.156÷.183	300÷360
IN-59/64	.156÷.183	290÷340
IN-1 5/32	.156÷.183	250÷300

CARBIDE CUTTER		
CODE	CUTTING SPEED m/min.	RPM
IN-1/4D	.316÷.383	950÷1100
IN-QD	.316÷.383	680÷850
IN-7/16D	.316÷.383	550÷650
IN-37/64D	.316÷.383	410÷500
IN-23/32D	.316÷.383	330÷400
IN-59/64D	.316÷.383	260÷310
IN-1 5/32D	.316÷.383	200÷250

MATERIALS HARDNESS

The standard cutters code IN-.. are made in rapid steel and titanium carbonitride coated. Such cutters can machine steel with maximum hardness of 40÷42 HRC; it is necessary to consider that as the hardness of the steel increases the working life of the cutter becomes significantly shorter. In order to meet the growing need to assembly cooling components on pre hardened inserts, a new set of cutters made in carbide steel and able to machine steel with hardness up to 50÷52 HRC is now available.

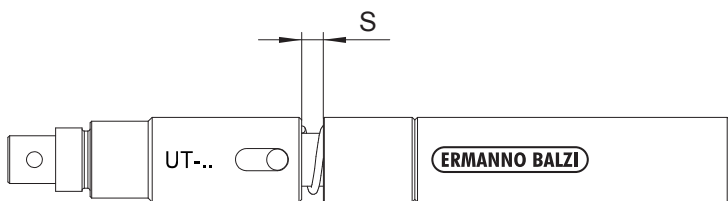

TOOL	S
UT-0	.169
UT-1	.169
UT-2	.169
UT-3	.185
UT-4	.200

ADVICES FOR THE CORRECT USE OF THE TOOL "UT"

1. The tool "UT" is designed to be used on machines where the forward movement is manually controlled.
2. The cutter starts the machining of the groove a few millimeters after the centering bush "BC" get in contact with the chamfer on the hole. Starting from this point the forward movement has to be slow.
3. The machining of the groove is completed when the gap "S" is completely closed by the forward movement of the tool.
4. Once the forward movement is completed neither making further pressure on the tool nor stopping in such a position more than a few seconds is advisable.

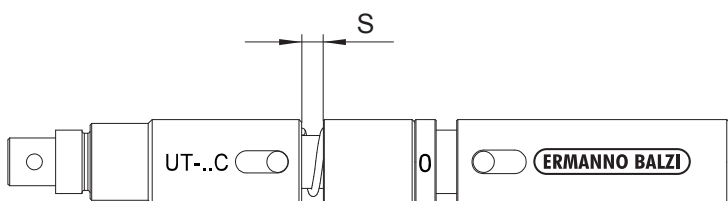

TOOL	S +.078 / +.118
UT-0C	.169
UT-1C	.169
UT-2C	.169
UT-3C	.185
UT-4C	.200

ADVICES FOR THE CORRECT USE OF THE TOOL "UT-C"

1. The tool "UT-C" is designed to be used on CNC machines where forward movement is automatically controlled.
2. It is possible to move in rapid traverse till .078 inc from the working position (contact point between centering bush "BC" and chamfer of the hole).
3. Starting from this point a cutting feed of 019 inc/turn is suggested.
4. The machining of the groove is completed when the gap "S" is completely closed by the forward movement of the tool. To guarantee the proper machining we suggest to set an extra stroke of .078÷.118 inc, the extra stroke will be compensated by a spring inside the tool.
5. Once the forward movement is completed neither making further pressure on the tool nor stopping in such a position more than a few seconds is advisable.

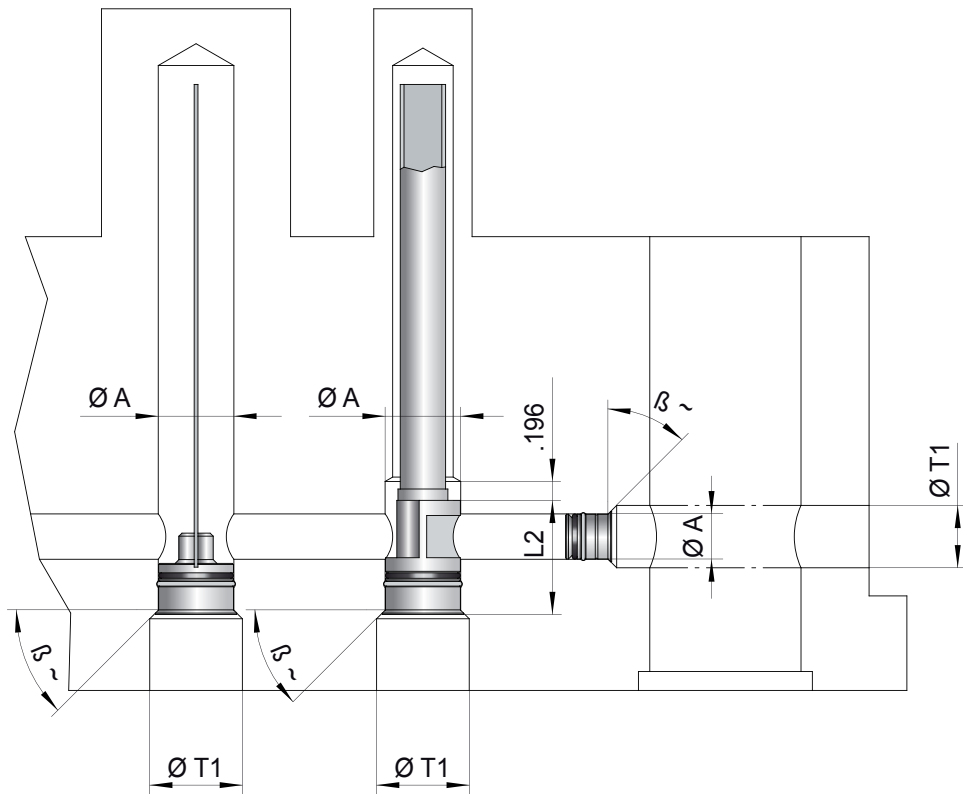

NOTE

1. In case of necessity to apply some elements in depth (as in the diagram above) and it is desired to execute the check canal using the appropriate tool, carry out the undercut ØT1 with the measures indicated in table.
2. The angle β (front inclination of the drill) should vary from a minimum of 0° to a maximum of 45° .
3. During the execution of a seat with double diameter (as in the diagram above), the depth of the ØA must be minimum .196 inch longer than the dimension «L2» of the bubbles.

DIMENSION ØA OF THE ITEM TO APPLY	ØT1	L2
.338	.511	.708
.437	.649	.866
.577	.688	.944
.718	.885	1.082
.921	.964	1.161
1.156	1.141	1.318

POSITIONING OF THE BUBBLES

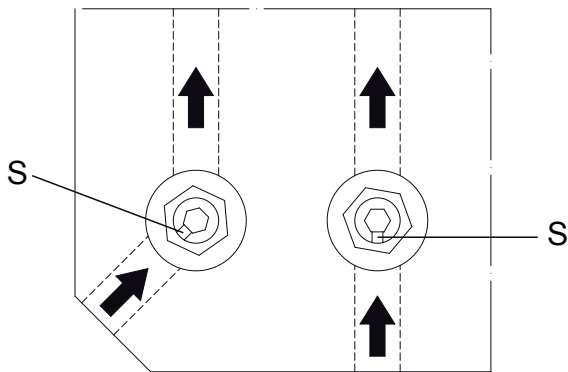

In order to obtain a correct circulation of the coolant, position the fiducial mark S that you can find on the bubble as indicated in the diagram.

POSITIONING OF THE BAFFLES

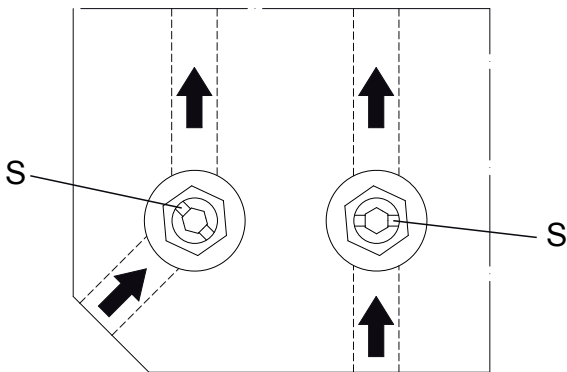

In order to obtain a correct circulation of the coolant, position the fiducial marks S that you can find on the baffle as indicated in the diagram. The fiducial marks correspond to the position of the blade.

INCHES SERIES TOOL BOX (tool without pressure compensation system)

CODE	INCHES SERIES SET COMPOSITION
UT	N°1 SINGLE TOOL
CE	N°1 SPECIAL HEXAGONAL KEY
CEB	N°1 "T" BETA KEY
BC	N°1 CENTERING BUSH FOR EACH SIZE
IN	N°1 CUTTER FOR EACH SIZE

Order example: CSI-7/16



CODE	CSI-1/4	CSI-Q	CSI-7/16	CSI-37/64	CSI-23/32	CSI-59/64	CSI-1"-5/32
UT-1	✓						
UT-2		✓					
UT-3			✓	✓			
UT-4					✓	✓	✓
BC-1/4	✓						
BC-Q		✓					
BC-7/16			✓				
BC-37/64				✓			
BC-23/32					✓		
BC-59/64						✓	
BC-1"-5/32							✓
IN-1/4	✓						
IN-Q		✓					
IN-7/16			✓				
IN-37/64				✓			
IN-23/32					✓		
IN-59/64						✓	
IN-1"-5/32							✓
CE-5	✓						
CE-6,5		✓					
CE-8			✓	✓			
CE-12					✓	✓	✓
CEB-2	✓						
CEB-2,5		✓					
CEB-3			✓	✓			
CEB-5					✓	✓	✓

INCHES SERIES TOOL BOX
(tool with pressure compensation system)



CODE	INCHES SERIES SET COMPOSITION
UTC	N°1 SINGLE TOOL
CE	N°1 SPECIAL HEXAGONAL KEY
CEB	N°1 "T" BETA KEY
BC	N°1 CENTERING BUSH FOR EACH SIZE
IN	N°1 CUTTER FOR EACH SIZE

Order example: CSI-7/16C

CODE	CSI-1/4C	CSI-QC	CSI-7/16C	CSI-37/64C	CSI-23/32C	CSI-59/64C	CSI-1"-5/32C
UT-1C	✓						
UT-2C		✓					
UT-3C			✓	✓			
UT-4C					✓	✓	✓
BC-1/4	✓						
BC-Q		✓					
BC-7/16			✓				
BC-37/64				✓			
BC-23/32					✓		
BC-59/64						✓	
BC-1"-5/32							✓
IN-1/4	✓						
IN-Q		✓					
IN-7/16			✓				
IN-37/64				✓			
IN-23/32					✓		
IN-59/64						✓	
IN-1"-5/32							✓
CE-5	✓						
CE-6,5		✓					
CE-8			✓	✓			
CE-12					✓	✓	✓
CEB-2	✓						
CEB-2,5		✓					
CEB-3			✓	✓			
CEB-5					✓	✓	✓