

ONLY FOR HIGH VISCOSITY MATERIALS

CODE	C	M	N	P
SGD-1410	1	2	0,5	/
SGDA-1410	1	2	0,5	/
SGD-1410C	1	2	/	0,5
SGD-1415	1,5	/	/	/

Mat.: AISI 420B

Hardness: 50÷52 HRC

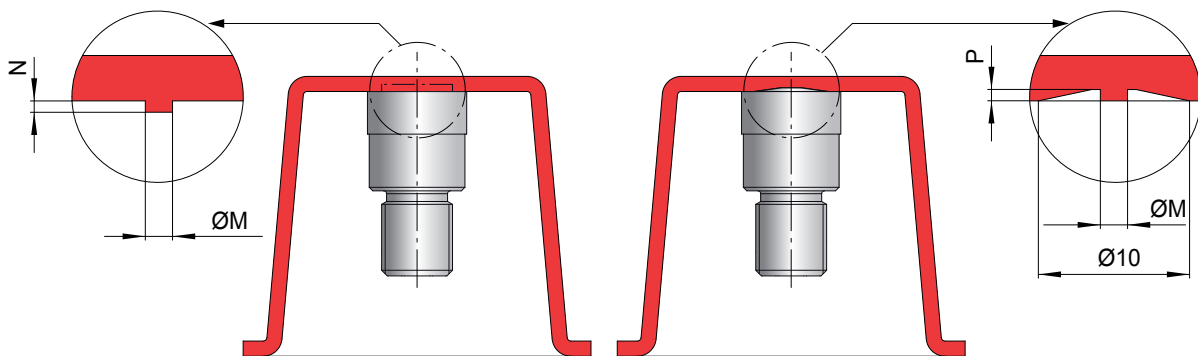

CHARACTERISTICS

1. HIGH VENTING CAPACITY;
2. VENTING SURFACE SLOWLY AFFECTED BY MOLD DEPOSITS;
3. IN CAVITY AIR BACK PRESSURE DRAMATICALLY REDUCED;
4. IMPROVEMENT OF AESTHETIC CHARACTERISTICS OF THE INJECTED PART;
5. POSSIBILITY OF FRONT DISASSEMBLY.

DYNAMIC GAS VENTING SYSTEM

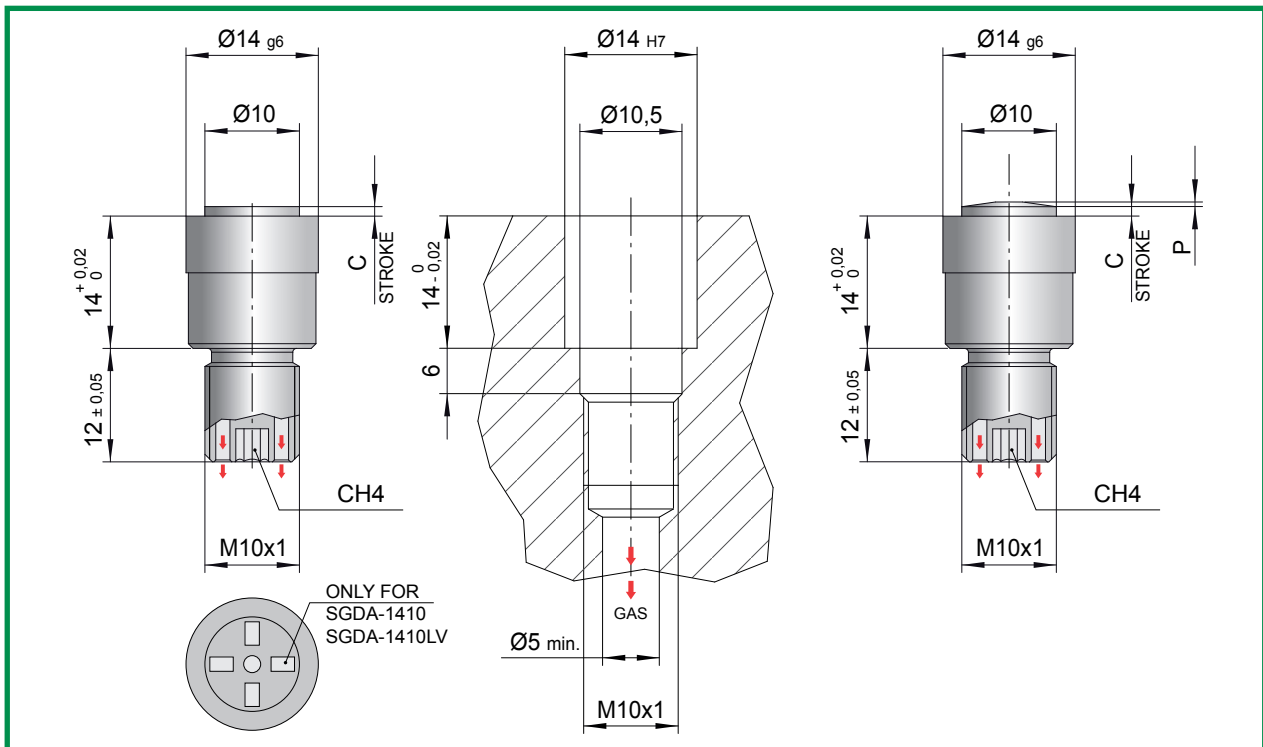

SUITABLE ALSO FOR LOW VISCOSITY MATERIALS

CODE	C	M	N	P
SGD-1410LV	1	1,2	0,5	/
SGDA-1410LV	1	1,2	0,5	/
SGD-1410CLV	1	1,2	/	0,5
SGD-1415LV	1,5	/	/	/

Mat.: AISI 420B

Hardness: 50÷52 HRC

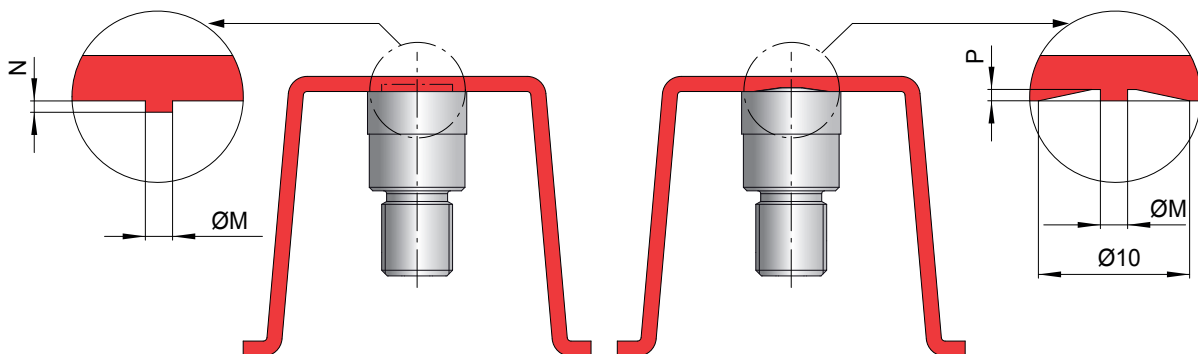

CHARACTERISTICS

1. HIGH VENTING CAPACITY;
2. VENTING SURFACE SLOWLY AFFECTED BY MOLD DEPOSITS;
3. IN CAVITY AIR BACK PRESSURE DRAMATICALLY REDUCED;
4. IMPROVEMENT OF AESTHETIC CHARACTERISTICS OF THE INJECTED PART;
5. POSSIBILITY OF FRONT DISASSEMBLY.

WORKING SYSTEM

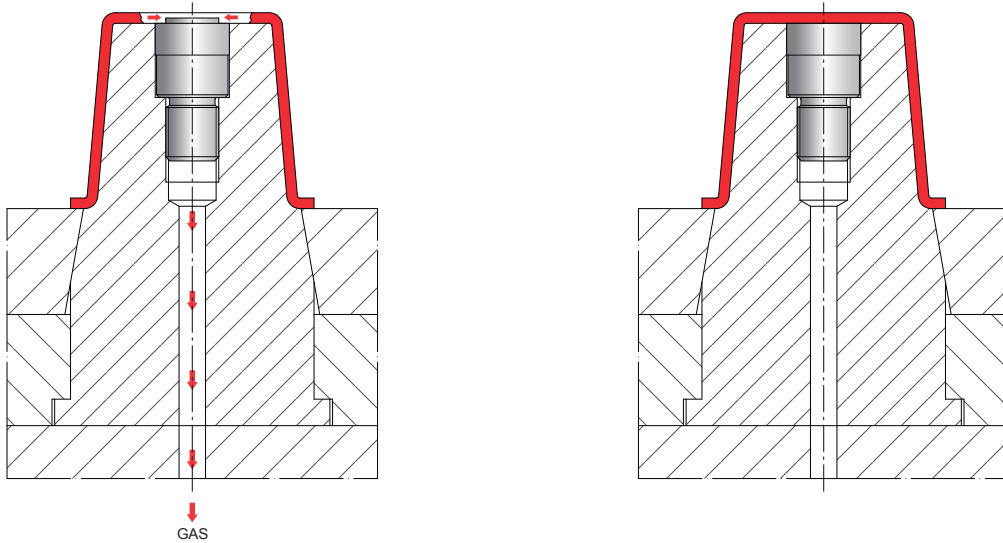

During the injection process the spring keeps the sliding insert in "open position" allowing the gases to pour out through the hole on the top of the valve. When the flow front reaches SGD the sliding insert moves back under plastic pressure to "close position" and closes the gas venting hole.

SHAPING MACHINING

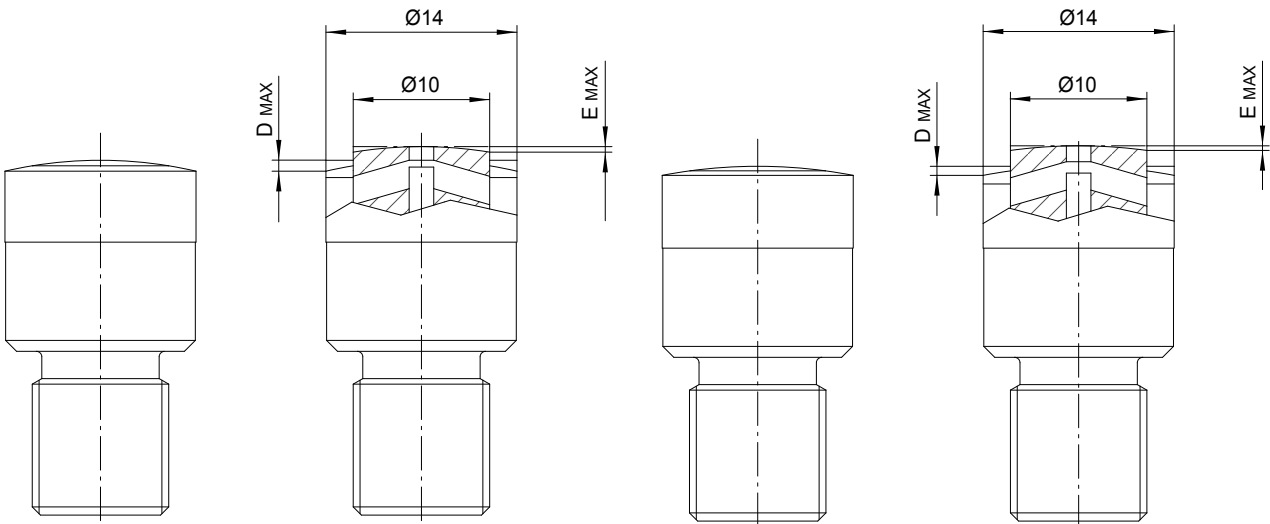

MODEL: SGD-1410

MODEL: SGD-1415

CODE	D	E
SGD-1410	0,8	0,4
SGD-1415	0,5	0,25

The SGD valve can be shaped within the maximum limit shown in the above picture.

FRONT UNSCREWING

The valve code SGDA-1410 can be screwed and unscrewed thanks to the special key code CS-SGDA. This application makes faster and simpler the valve maintenance procedure.

CODE: **CS-SGDA**

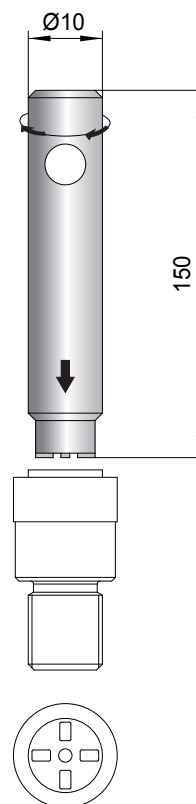

The top surface of the valve type SGDA-1410 is machined to fit the key code CS-SGDA.

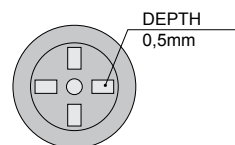

Such special machining creates four protrusions thickness 0,5 mm on the injected part.

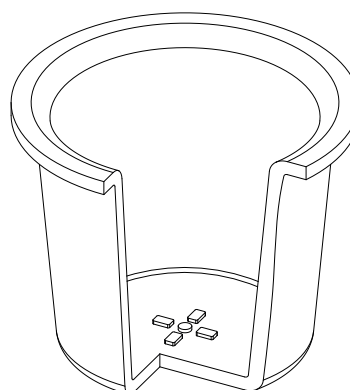

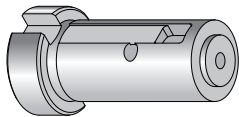
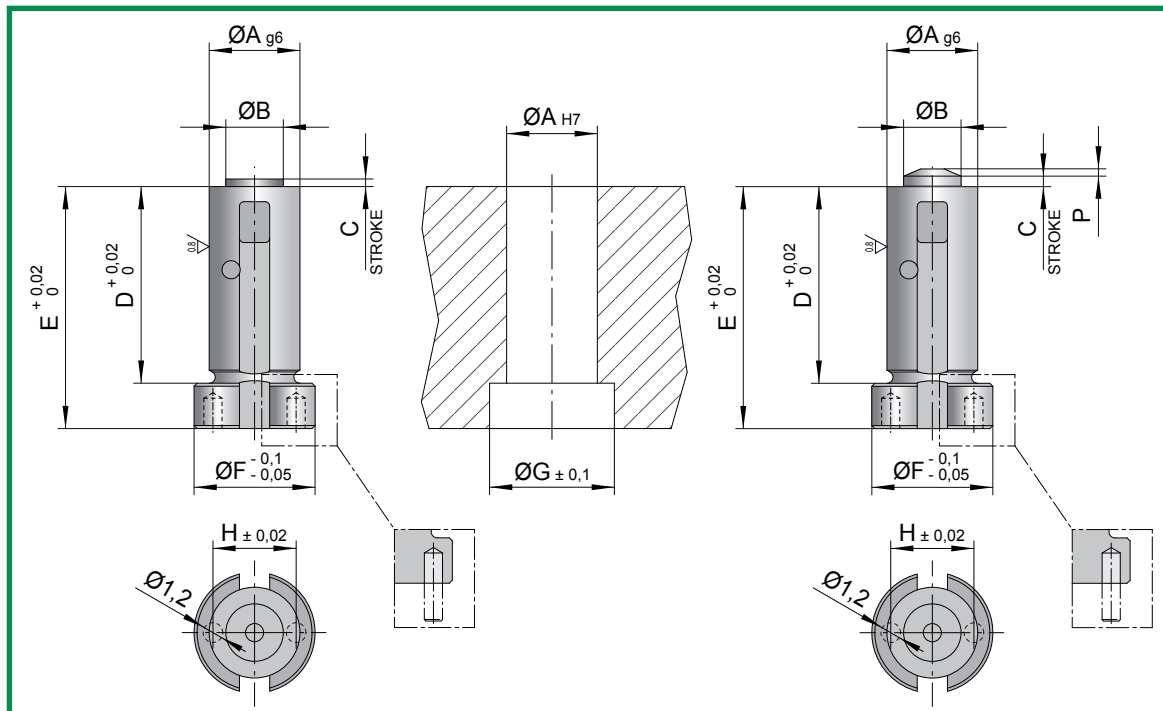

CODE: **SGD-605 / SGD-608**

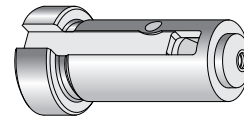

CODE: **SGD-607C**

CODE	A	B	C	D	E	F	G	H	M	N	P
SGD-605	6	4	0,5	13	16	8	8,5	5,5	1,2	0,3	/
*SGD-608	6	4	0,8	13	16	8	8,5	5,5	/	/	/
SGD-607C	6	4	0,7	13	16	8	8,5	5,5	1,2	/	0,5

Mat.: AISI 420B

Hardness: 50±52 HRC

* It is necessary to inject an air blast after ejection of plastic part. (See technical notes)

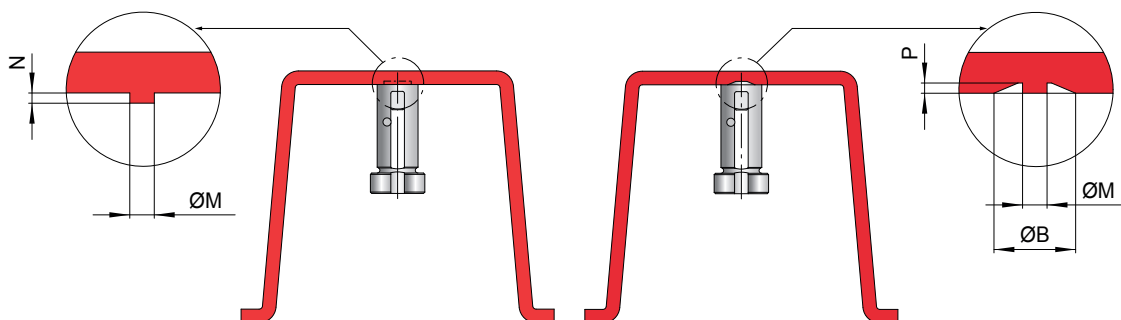

CHARACTERISTICS

1. HIGH VENTING CAPACITY;
2. VENTING SURFACE SLOWLY AFFECTED BY MOLD DEPOSITS;
3. IN CAVITY AIR BACK PRESSURE DRAMATICALLY REDUCED;
4. IMPROVEMENT OF AESTHETIC CHARACTERISTICS OF THE INJECTED PART.

SHAPING MACHINING

The SGD-6.. valves can be shaped within the maximum limit shown in the above picture.

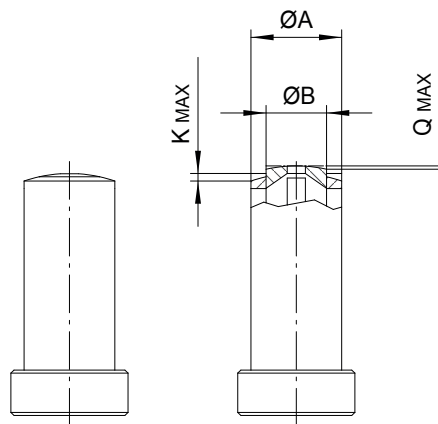

CODE	A	B	K	Q
SGD-605	6	4	0,5	0,25
SGD-608	6	4	0,5	0,25

APPLICATION EXAMPLE

The valve type SGD-6.. has to be fixed into the mold insert from the back side. The spacer code D-SGD and the dowel code G-SGD can make this application easier.

The spacer is specially designed to collect the gases from the valve toward a central hole that communicates with the open atmosphere. It is possible to machine the spacer in order to reach the desired length.

The dowel allows to fix the spacer and the valve and collects the gases into the central hole.

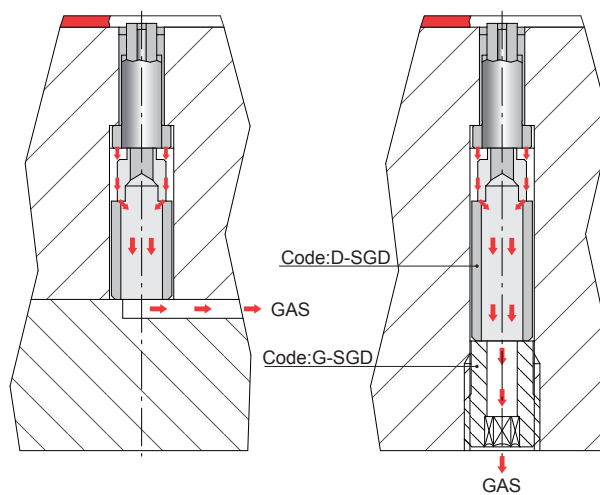

For a correct application of the venting valve code: SGD-608 it is necessary to inject an air blast after ejection of plastic part, the air will guarantee the valve to open every shot. With a normally open 3/2 valve it is possible to use the gas venting channel also to inject the air blast.

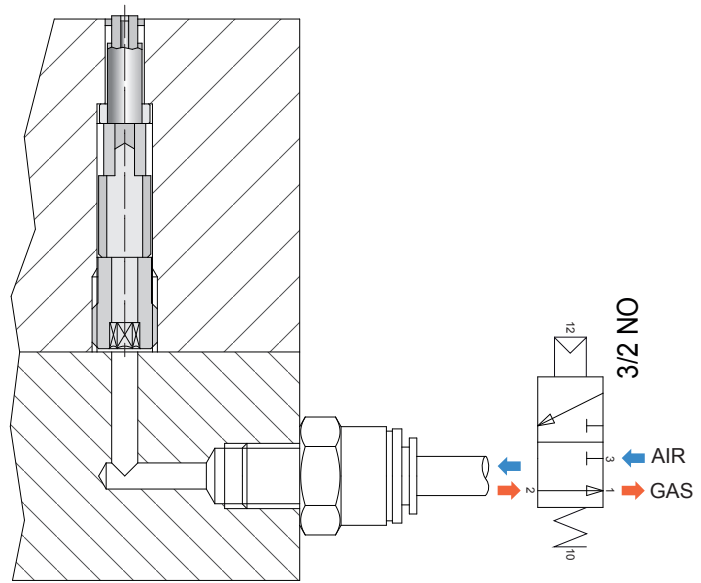

Some polymeric materials produce remarkable gas volume during melting process. Oily gas deposits can pile up and obstruct the gas venting channels. It is possible to machine extra gas venting channel in the mold as shown in the picture to improve valve performance.

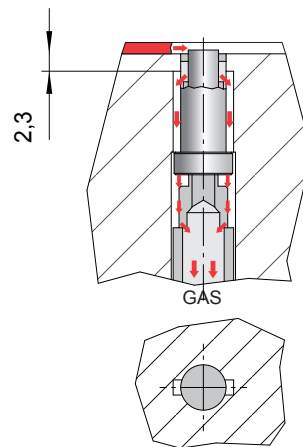

DYNAMIC GAS VENTING SYSTEM

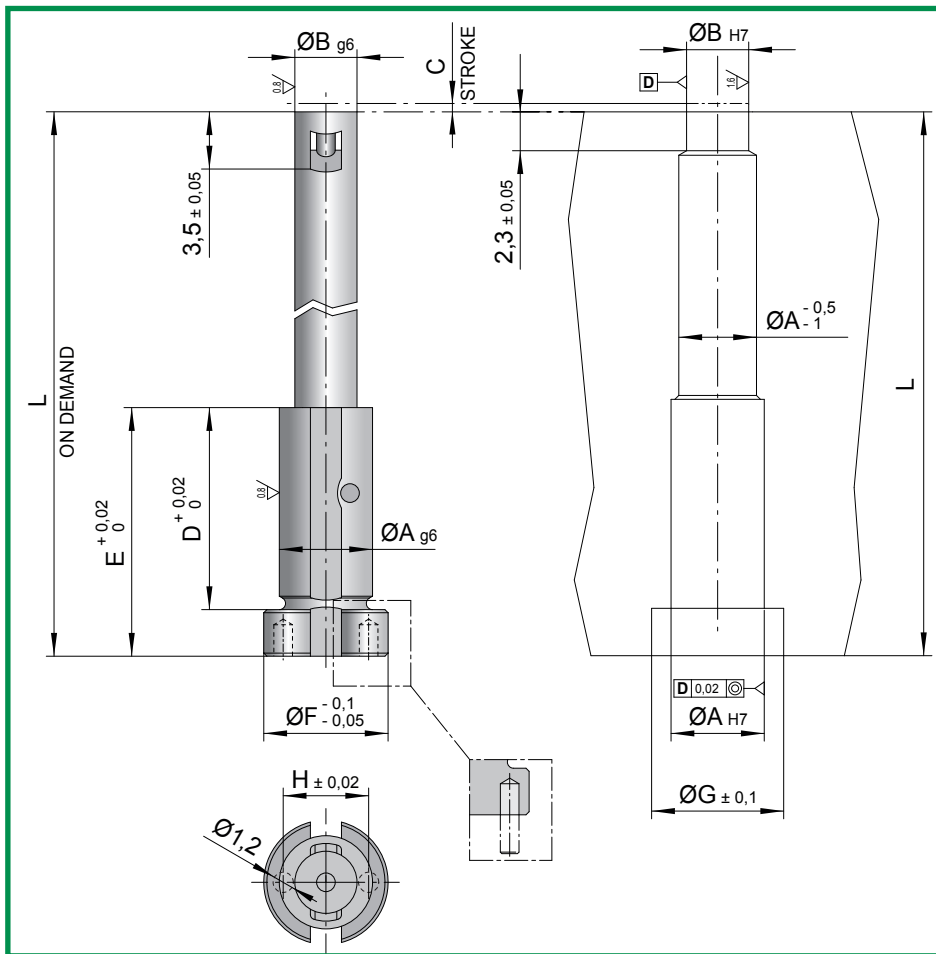

CODE: **SGDL-...**

CODE	A	B	C	D	E	F	G	H	L (min)	L (max)	M	N
SGDL-605	6	4	0,5	13	16	8	8,5	5,5	20	105	1,2	0,3
*SGDL-608	6	4	0,8	13	16	8	8,5	5,5	20	105	/	/

Mat.: AISI 420B

Hardness: 50+52 HRC

* It is necessary to inject an air blast after ejection of plastic part. (See technical notes)

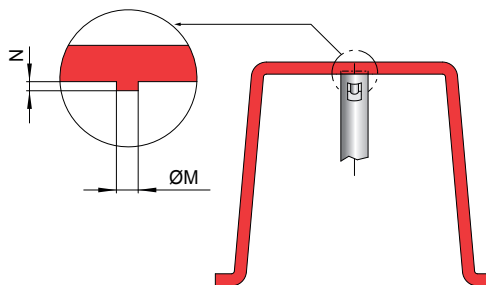

CHARACTERISTICS

1. HIGH VENTING CAPACITY;
2. VENTING SURFACE SLOWLY AFFECTED BY MOLD DEPOSITS;
3. IN CAVITY AIR BACK PRESSURE DRAMATICALLY REDUCED;
4. IMPROVEMENT OF AESTHETIC CHARACTERISTICS OF THE INJECTED PART;
5. LIMITED DIMENSIONS;
6. MAXIMUM AVAILABLE LENGTH 105mm.

ERMANN BALZI

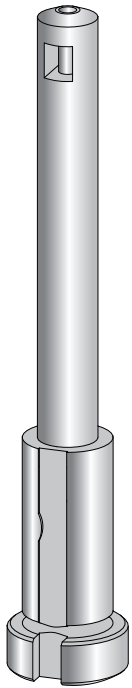

CODE: **SGDL-607C**

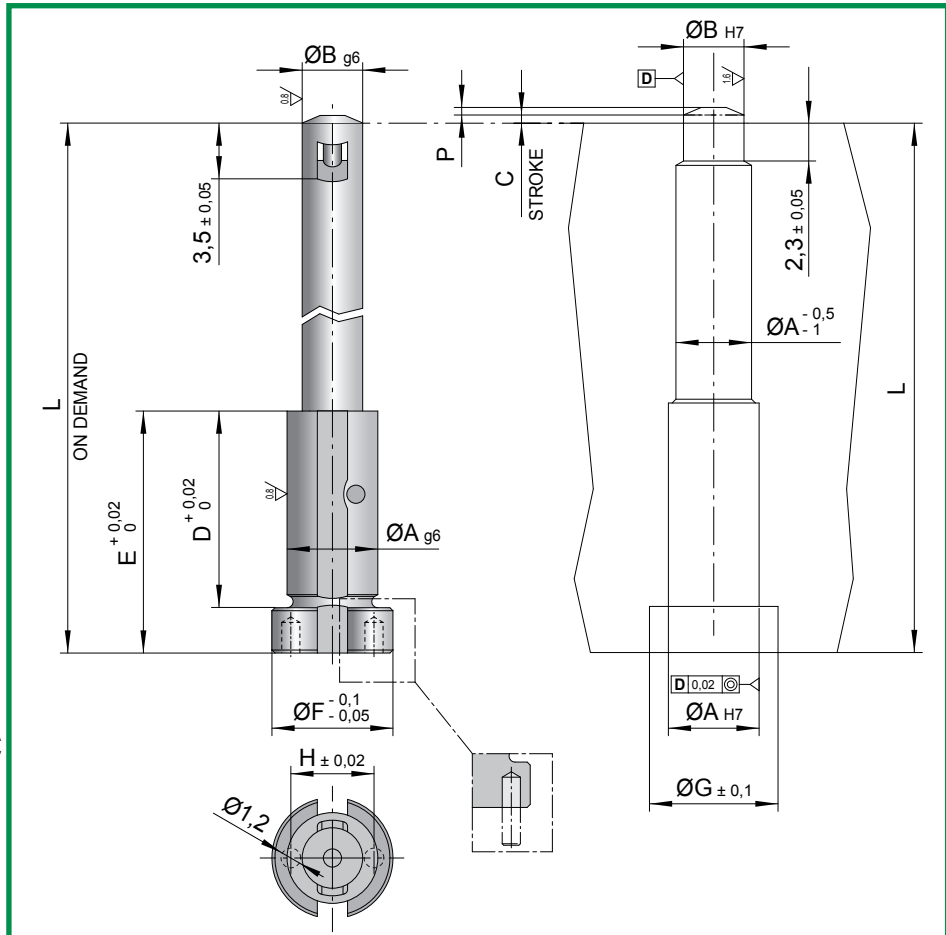

CODE	A	B	C	D	E	F	G	H	L (min)	L (max)	M	N	P
SGDL-607C	6	4	0,7	13	16	8	8,5	5,5	20	105	1,2	/	0,5

Mat.: AISI 420B
Hardness: 50÷52 HRC

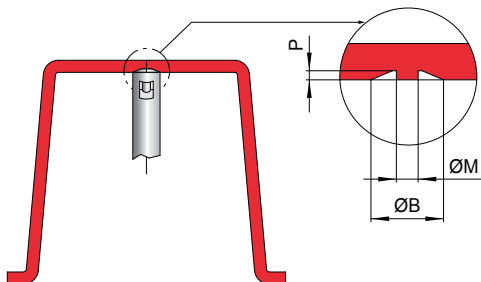

CHARACTERISTICS

1. HIGH VENTING CAPACITY;
2. VENTING SURFACE NOT AFFECTED BY MOLD DEPOSITS;
3. IN CAVITY AIR BACK PRESSURE DRAMATICALLY REDUCED;
4. IMPROVEMENT OF AESTHETIC CHARACTERISTICS OF THE INJECTED PART;
5. LIMITED DIMENSIONS;
6. MAXIMUM AVAILABLE LENGTH 105mm.

The valve type SGDL has to be fixed into the mold insert from the back side and the valve needle has to stick out from the mold surface for a dimension equal to the stroke "C". The spacer code D-SGD.. and the dowel code G-SGD.. can make this application easier. The spacer is specially designed to collect the gases from the valve toward a central hole that communicates with the open atmosphere. It is possible to machine the spacer in order to reach the desired length. The dowel allows to fix the spacer and the valve and collects the gases into the central hole.

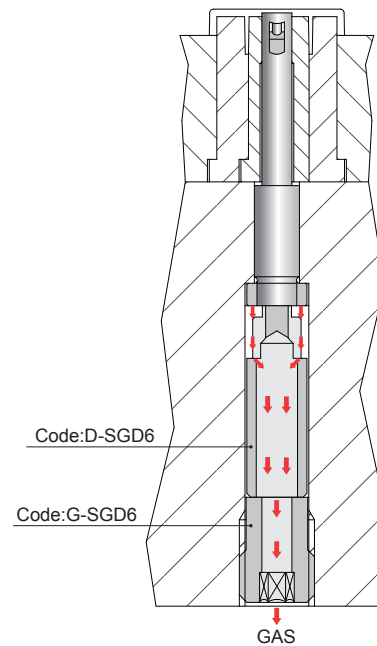

For a correct application of the venting valve Code: SGDL-608 it is necessary to inject an air blast after ejection of plastic part, the air will guarantee the valve to open every shot.

With a normally open 3/2 valve it is possible to use the gas venting channel also to inject the air blast.

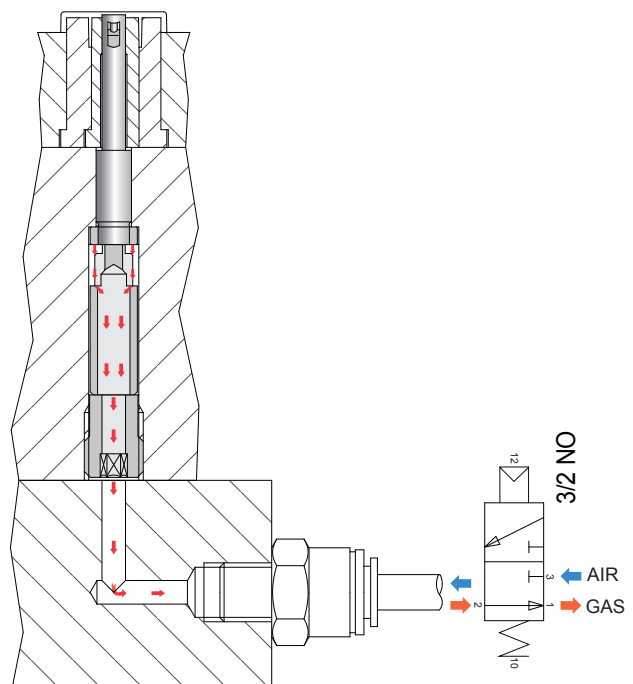

SPACER FOR GAS VENTING VALVE

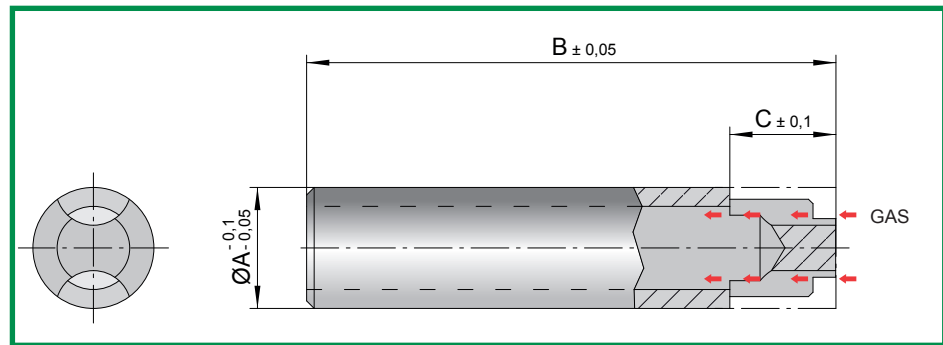

CODE: **D-SGD..**

CODE	A	B	C
D-SGD6	8	50	7

Mat.: carbon steel. Hardness: 750 N/mm² (220 HB)
Nitred depth 0,1mm

DOWEL FOR GAS VENTING VALVE

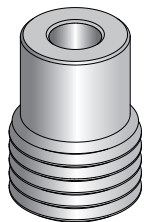

CODE: **G-SGD..**

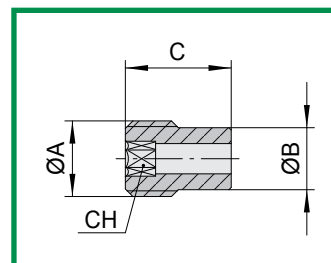

CODE	A	B	C	CH
G-SGD6	M10	8,3	14	4

Mat.: 7225. Hardness: 750 N/mm² (220 HB)
Nitred depth 0,1mm

DYNAMIC GAS VENTING SYSTEM

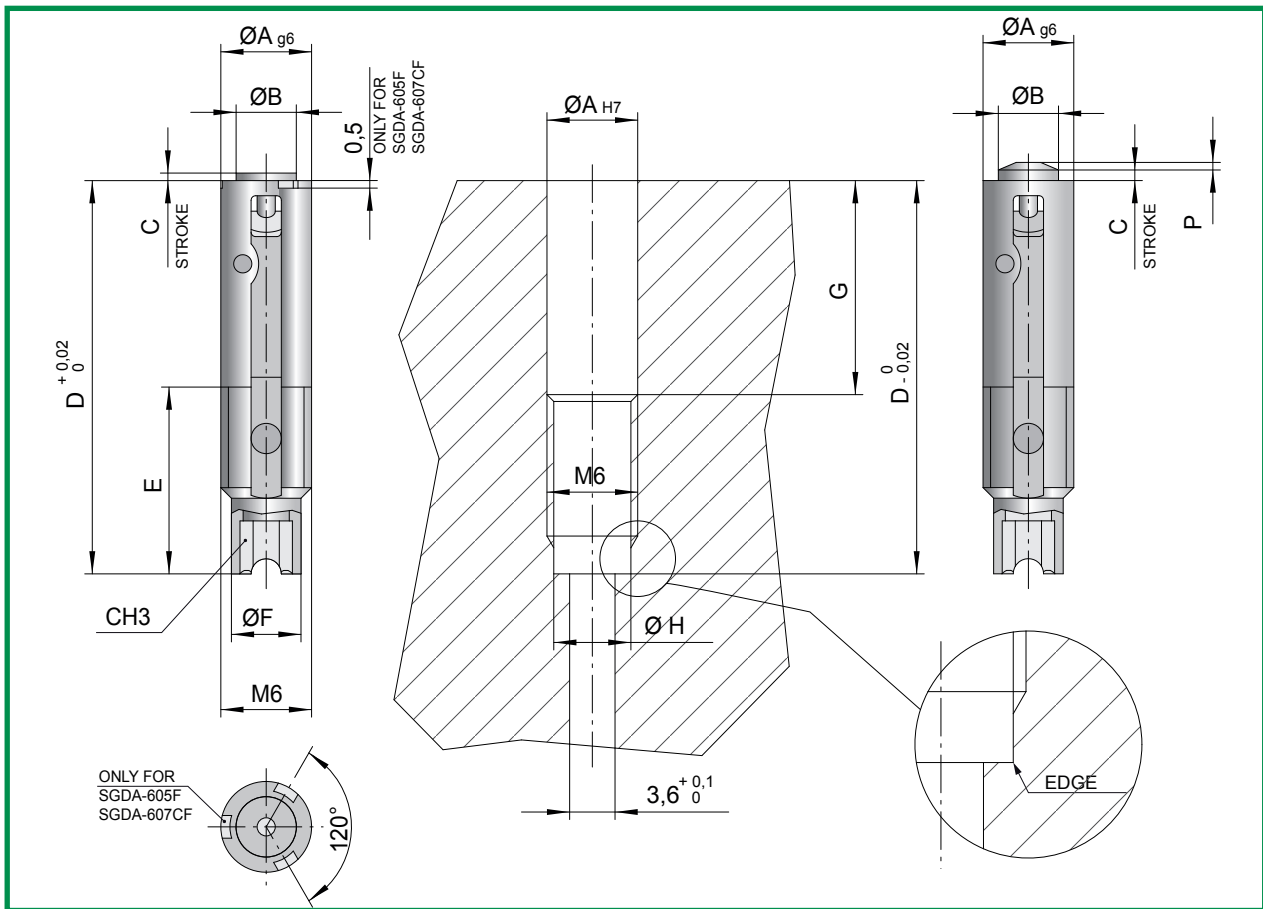

CODE	A	B	C	D	E	F	G	H	M	N	P
SGD-605F	6	4	0,5	26	12	4,6	15	5,1	1,2	0,3	/
SGDA-605F	6	4	0,5	26	12	4,6	15	5,1	1,2	0,3	/
*SGD-608F	6	4	0,8	26	12	4,6	15	5,1	/	/	/
SGD-607CF	6	4	0,7	26	12	4,6	15	5,1	1,2	/	0,5
SGDA-607CF	6	4	0,7	26	12	4,6	15	5,1	1,2	/	0,5

Mat.: AISI 420B Hardness: 50±52 HRC

* It is necessary to inject an air blast after ejection of plastic part. (See technical notes)

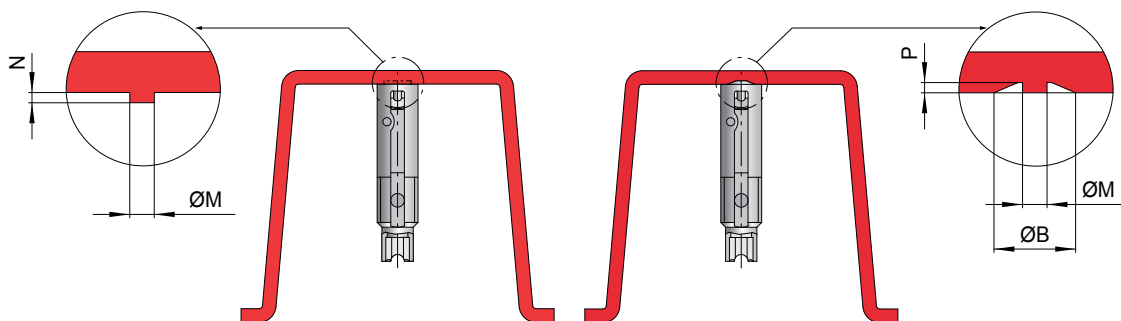

CHARACTERISTICS

1. HIGH VENTING CAPACITY;
2. CAVITY AIR COUNTER PRESSURE DRAMATICALLY REDUCED;
3. IMPROVEMENT OF PART'S AESTHETIC CHARACTERISTICS;
4. POSSIBILITY OF FRONT DISASSEMBLY.

ERMANN BALZI

FRONT UNSCREWING

The valve code SGDA-605F can be screwed and unscrewed thanks to the special key code CS-SGDAF. This application makes faster and simpler the valve maintenance procedure.

CODE: **CS-SGDAF**

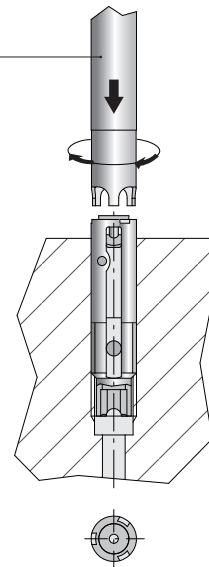

CLEANING AND MAINTENANCE

It is possible to disassembly the dynamic venting valve with the following procedure:

- remove the assembly pin 6;
- remove the sliding shaft 2 and the spring 7;
- unscrew the internal dowel 3;
- remove the pin for body fixing 5 and central pin 4.

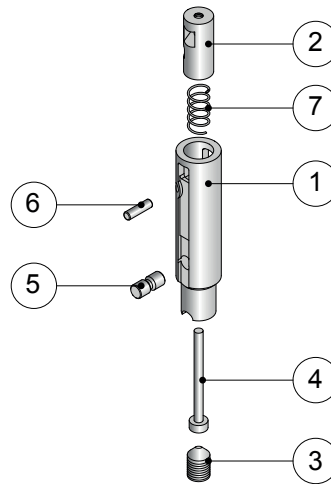

TECHNICAL INSTRUCTIONS FOR THE APPLICATION OF CODE SGD-608F

For a correct application of the venting valve code: SGD-608F it is necessary to inject an air blast after ejection of plastic part, the air will guarantee the valve to open every shot. With a normally open 3/2 valve it is possible to use the gas venting channel also to inject the air blast.

