

CODE: **UM-..**

CODE	A	B	C	D	E	F	G	H	L	M
UM-14-..	14	12	14	5	2,3	M4	8,5	5	2	0,15
UM-18-..	18	16	18	6	3	M5	9,5	6,5	2	0,15
UM-24-..	24	20	22	7,5	3,4	M5	9,5	8	3	0,15
UM-30-..	30	26	25	7	3	M5	11,5	10	3	0,15

Mat.: AISI 420B
Hardness: 50÷52 HRC

CHARACTERISTICS

1. FRONT ASSEMBLY AND REMOVAL SYSTEM;
2. QUICK INSERT CHANGE;
3. CUSTOM ENGRAVINGS ON DEMAND.



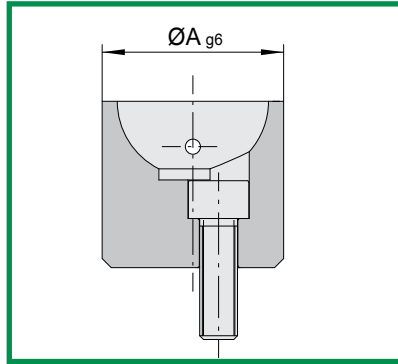



MARKING UNIT HOUSING

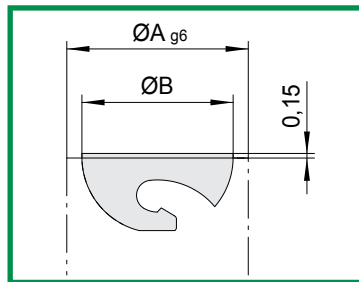

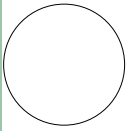
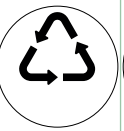
A	HOUSING CODE
14	UMC-14
18	UMC-18
24	UMC-24
30	UMC-30

MARKING UNIT INSERT

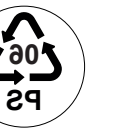

A	B	INSERT CODE							
									
		N	00	01	02	03	04	05	06
14	12	UMI-12N	UMI-1200	UMI-1201	UMI-1202	UMI-1203	UMI-1204	UMI-1205	UMI-1206
18	16	UMI-16N	UMI-1600	UMI-1601	UMI-1602	UMI-1603	UMI-1604	UMI-1605	UMI-1606
24	20	UMI-20N	UMI-2000	UMI-2001	UMI-2002	UMI-2003	UMI-2004	UMI-2005	UMI-2006
30	26	UMI-26N	UMI-2600	UMI-2601	UMI-2602	UMI-2603	UMI-2604	UMI-2605	UMI-2606

Depth marking: 0,15mm

Custom marking on demand (laser engravings)

EXAMPLE CODE OF A COMPLETE MARKING UNIT

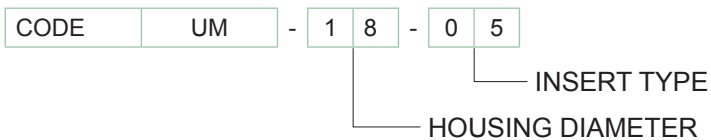

MARKING UNIT TOOL

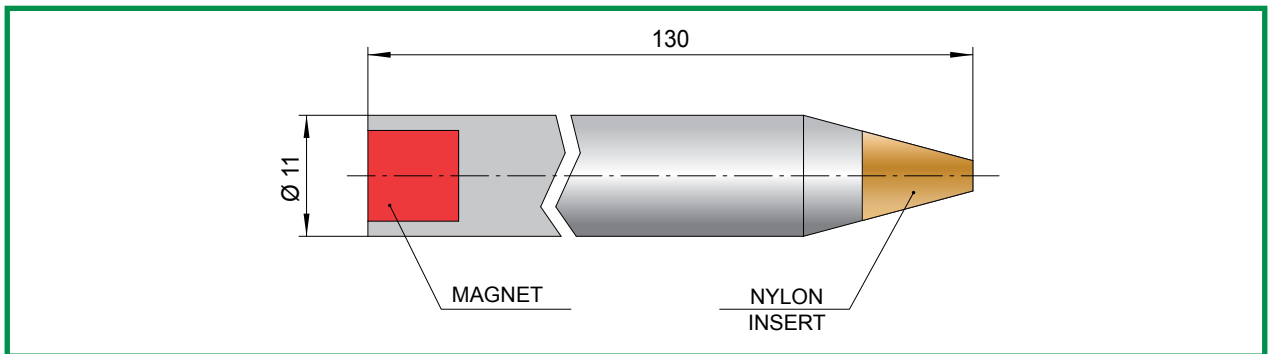

CODE: **UMP**

MARKING UNIT ORIENTATION

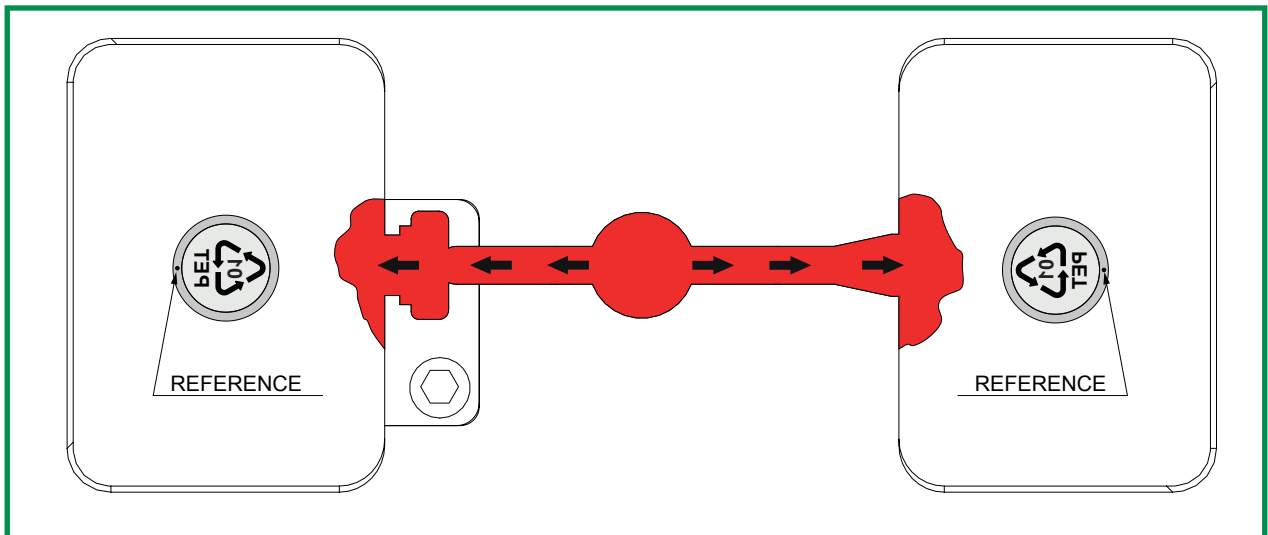

- For proper operation, place the marking unit with the reference mark oriented in the opposite direction to the arrival of the plastic flow front.

ASSEMBLY PROCEDURE

- Insert the housing into the mould seat and fix it with the fixing screw.

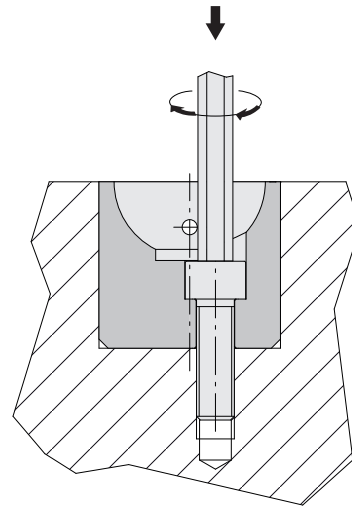

- Place the insert into the housing the hooking tooth in contact with the locking pin. Apply a force with the proper tool and make the insert tilt to the locking position.

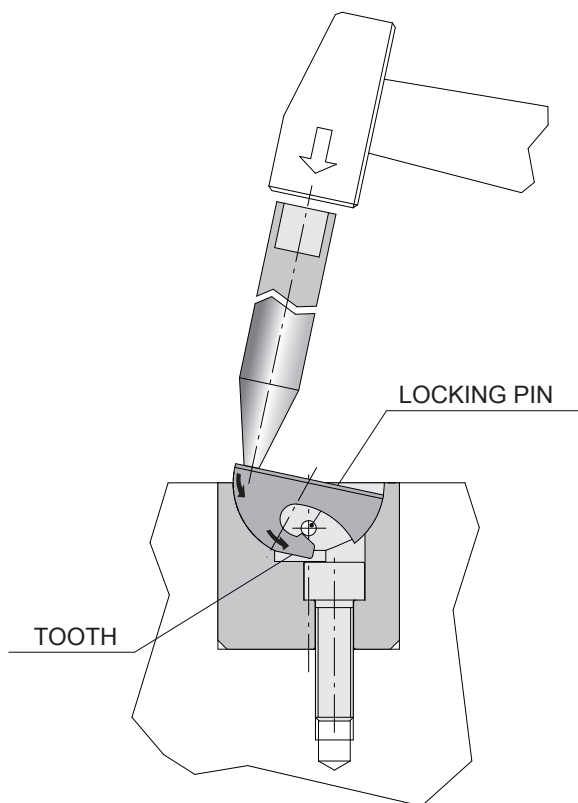

LOCKING POSITION

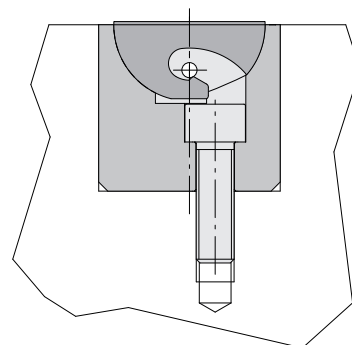

DISASSEMBLY PROCEDURE

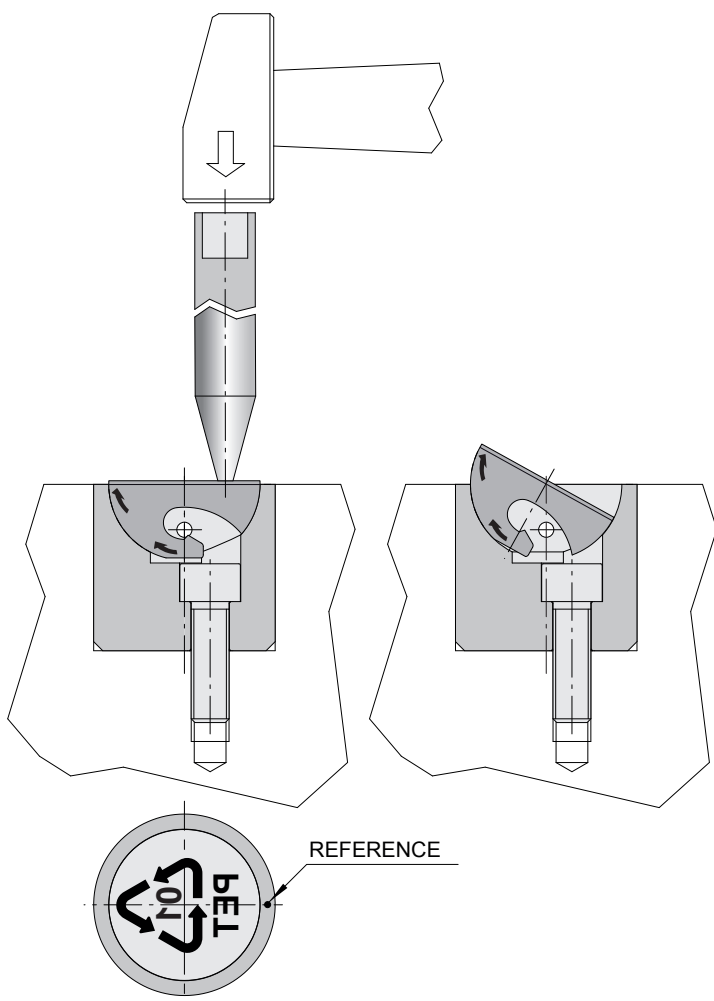

- Apply a force on the insert close to the reference point.

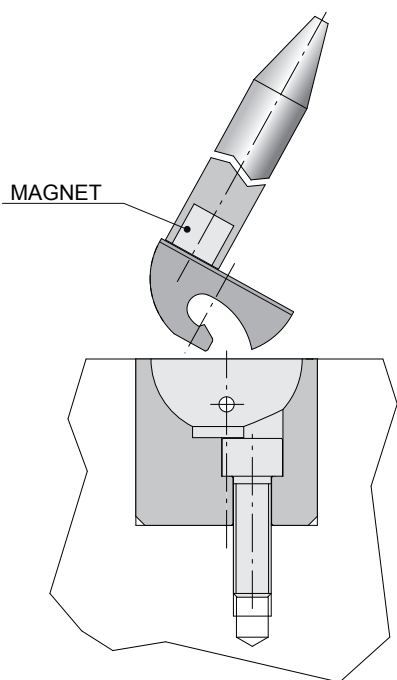

- The magnet on the back of the tool helps to remove the insert.