

编号: **VA**

编号	A	B	L	L1	C	D	E
VA-4	4	3,4	8	4	3,5	2,8	3
VA-6	6	5	10	4	5	4	4,5
VA-6L	6	5	12	4	5	4	4,5
VA-8	8	5,6	12	4	6,5	5	6
VA-10	10	8	14	5	7,5	5	7
VA-10C	10	8	12	5	7,5	5	7
VA-12	12	10	14	5	9	5,5	8,5
VA-12C	12	10	12	5	9	5,5	8,5
VA-16	16	12	20	6	12	6,5	11
VA-20	20	16	20	6	12	6,5	11

## 关于空气阀拆卸的技术说明

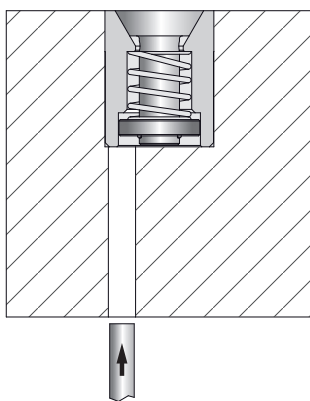

解决方案1

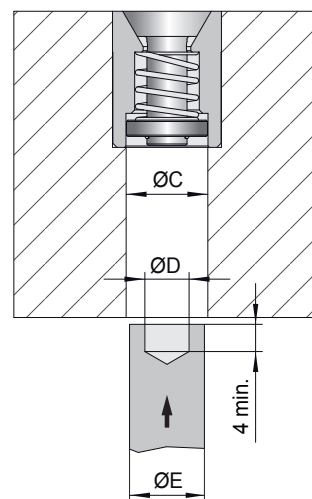

解决方案2

## 特点

1. 不锈钢, AISI 420 50-55 HRC;
2. 整体打磨;
3. 结构紧凑 (防止拆卸时发生损坏).