

Application with dual pneumatic power supply

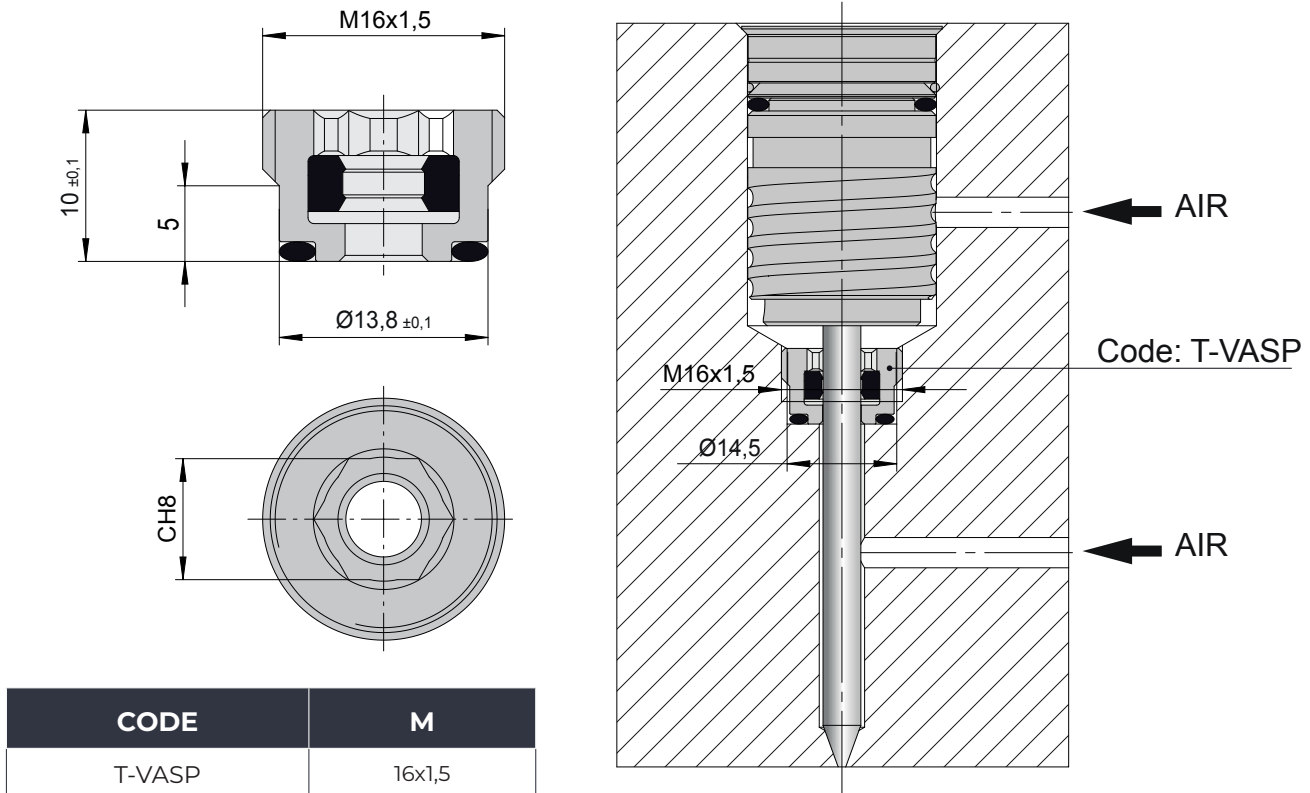

To optimize the operation of the needle valve VASP, it is possible to apply the T-VASP stem seal in order to create a dedicated chamber for retraction that is isolated from the air delivery channel in the cavity. This application can also be useful in case the VASP valve is intended to aspirate air from the cavity to create a vacuum before molding.